

**RIGHT ANGLE H2.6 RECEPTACLE NON-MAGNETIC
SMT TYPE
REEL 3300**

R107.103.087

Series : UMP

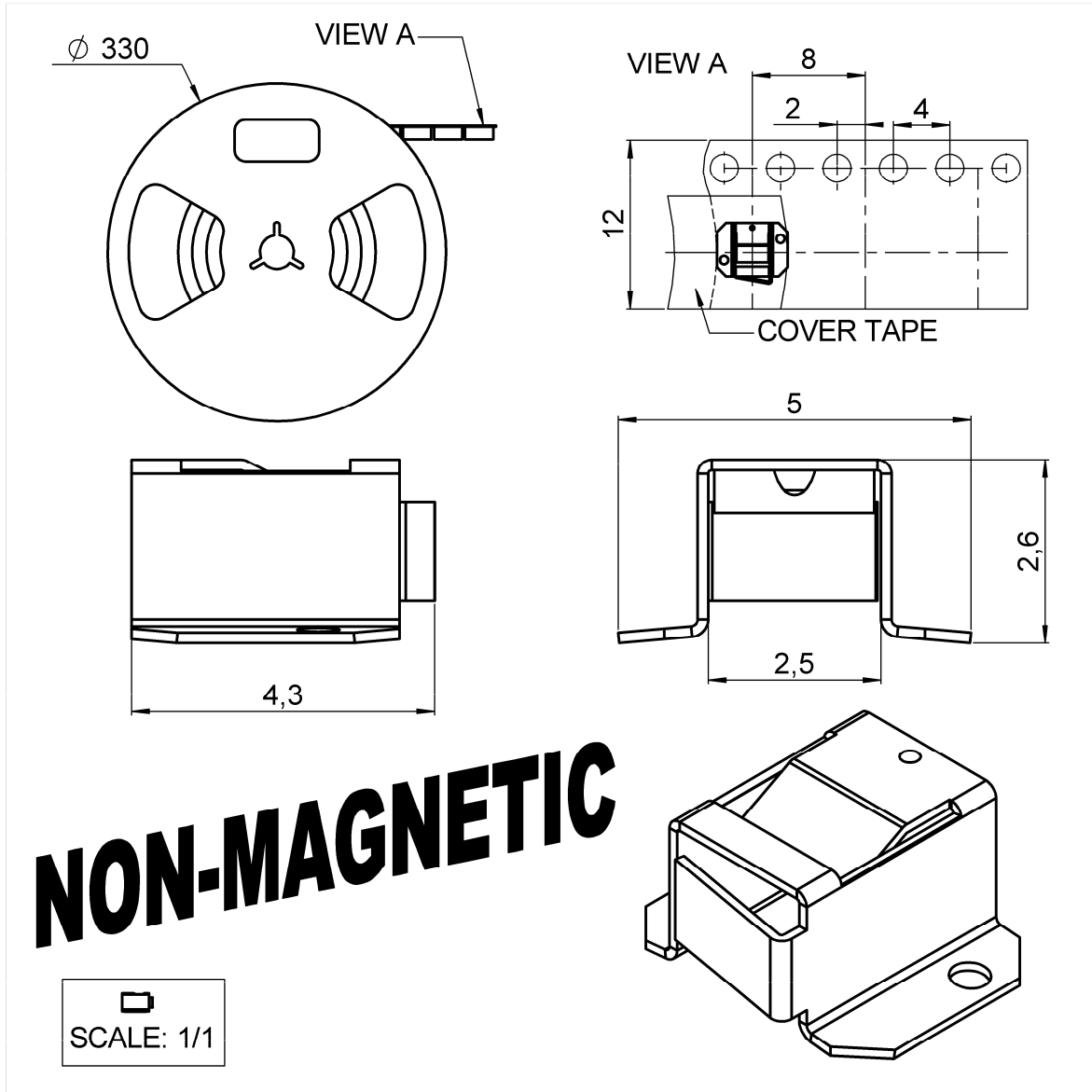

All dimensions are in mm.

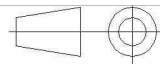

COMPONENTS	MATERIALS	PLATING (µm)
BODY	BERYLLIUM COPPER	TIN
CENTER CONTACT	-	-
OUTER CONTACT	-	-
INSULATOR	-	-
GASKET	-	-
OTHERS PARTS	-	-
-	-	-
-	-	-

Issue : 0707 A

In the effort to improve our products, we reserve the right to make changes judged to be necessary.



**RIGHT ANGLE H2.6 RECEPTACLE NON-MAGNETIC
SMT TYPE
REEL 3300**

R107.103.087

Series : UMP

PACKAGING

Standard	Unit	Other
3300		Contact us

SPECIFICATION

PAQP-VOR-017

ELECTRICAL CHARACTERISTICS

Impedance **50** Ω
 Frequency **0-6** GHz
 VSWR **1.05 + 0,0300** x F(GHz) Maxi
 Insertion loss **NA** √F(GHz) dB Maxi
 RF leakage - (**NA** - F(GHz)) dB Maxi
 Voltage rating **100** Veff Maxi
 Dielectric withstanding voltage **350** Veff mini
 Insulation resistance **1000** MΩ mini

ENVIRONMENTAL

Operating temperature **-40/+55** ° C
 Hermetic seal **NA** Atm.cm3/s
 Panel leakage **NA**

OTHER CHARACTERISTICS

Assembly instruction **NA**

Others :
 magnetic fields distorsions
 <0.5 ppm at 10mm at Bo=1.5 Tesla

MECHANICAL CHARACTERISTICS

Center contact retention
 Axial force – Mating end - N mini
 Axial force – Opposite end - N mini
 Torque - N.cm mini

Recommended torque
 Mating - N.cm
 Panel nut - N.cm

Mating life **100** Cycles mini
 Weight **0,0500** g

Issue : 0707 A

In the effort to improve our products, we reserve the right to make changes judged to be necessary.



**RIGHT ANGLE H2.6 RECEPTACLE NON-MAGNETIC
SMT TYPE
REEL 3300**

R107.103.087

Series : UMP

SOLDER PROCEDURE OF UMP RECEPTACLE IN INDUSTRIAL ENVIRONMENT

1. Deposit solder paste 'Sn Ag4 Cu0.5' on mounting zone by screen printing application. We recommend a low residue flux.
We advise a thickness of 150 micromm (5.850 microinch). Verify that the edges of the zone are clean.
2. Placement of the receptacle on the mounting zone with an automatic machine of 'pick and place' type.
A video camera is recommended for positioning of the component.
Adhesive agents must not be used on the receptacle.
3. This process of soldering has been tested with convection oven.
Below please find, the typical profile to use.
4. The cleaning of printed circuit boards is not obliged.
5. Verification of solder joints and position of the component by visual inspection.

NOTE : THE UMP RECEPTACLE AND THE UMP PLUG MUST NOT BE MATED BEFORE COMPLETION OF THIS PROCEDURE.

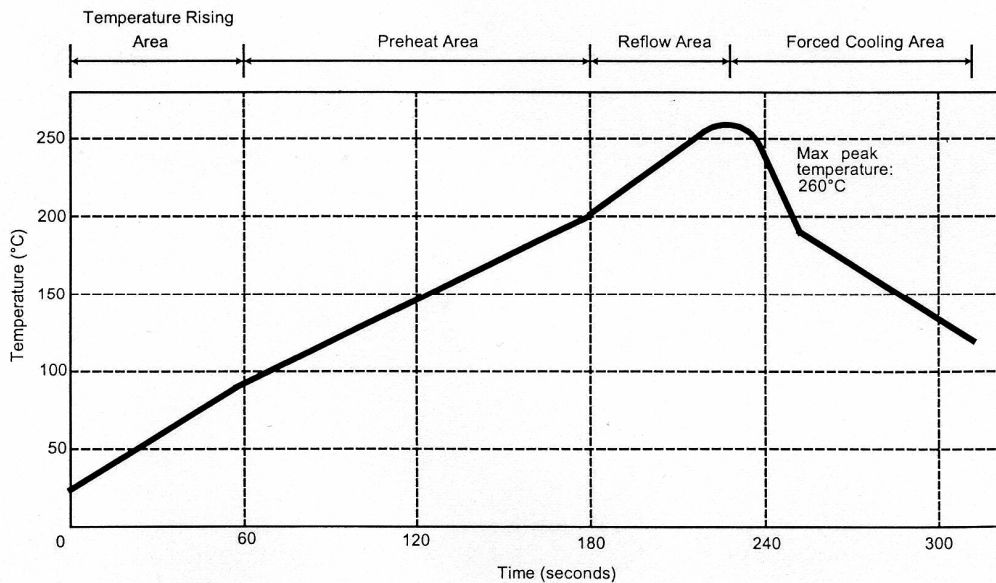

Parameter	Value	Unit
Temperature rising Area	1 - 4	°C/sec
Max Peak Temperature	260	°C
Max dwell time @260°C	10	sec
Min dwell time @235°C	20	sec
Max dwell time @235°C	60	sec
Temperature drop in cooling Area	-1 to - 4	°C/sec
Max dwell time above 100°C	420	sec

Issue : 0707 A

In the effort to improve our products, we reserve the right to make changes judged to be necessary.



**RIGHT ANGLE H2.6 RECEPTACLE NON-MAGNETIC
SMT TYPE
REEL 3300**

R107.103.087

Series : UMP

UMP SERIES INFORMATION

PCB

COPLANAR LINE

Ground and signal are on the same side

Thickness of PCB : 1 mm

The material of PCB is glass is glass-epoxy

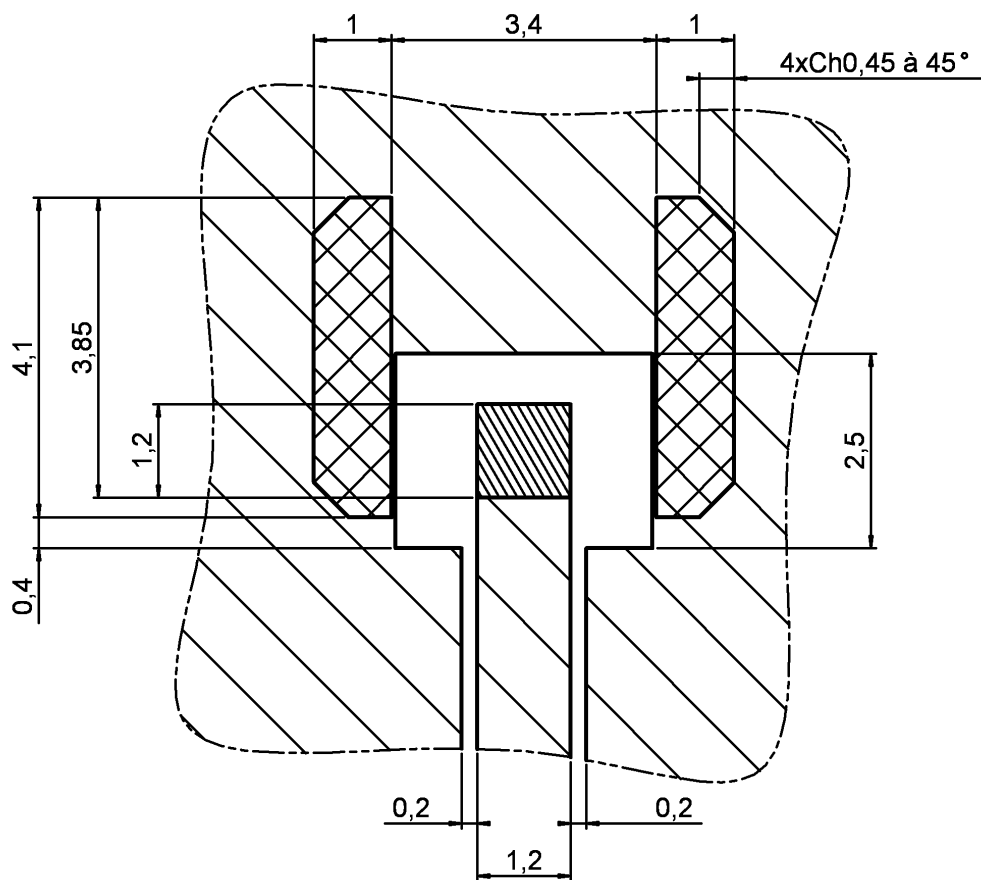

 18µm Cu mini + 7 to 9µm Sn

 18µm Cu mini + 7 to 9µm Sn

 Ground + varnish

Composite. (Er=4.8)

Issue : 0707 A

In the effort to improve our products, we reserve the right to make changes judged to be necessary.



**RIGHT ANGLE H2.6 RECEPTACLE NON-MAGNETIC
SMT TYPE
REEL 3300**

R107.103.087

Series : UMP

UMP SERIES INFORMATION

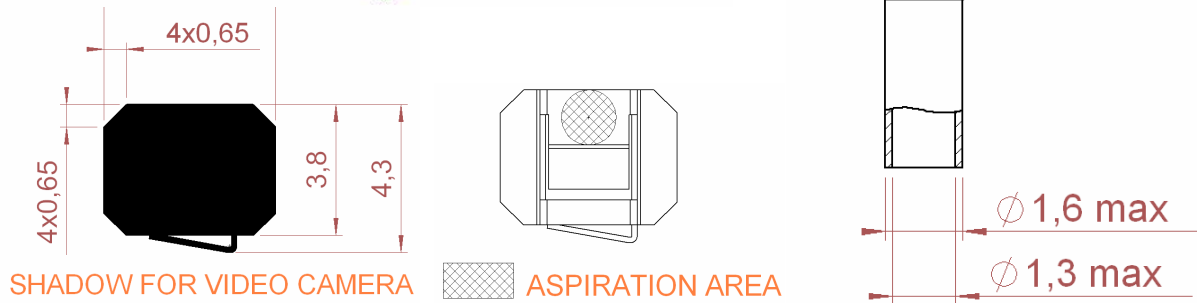
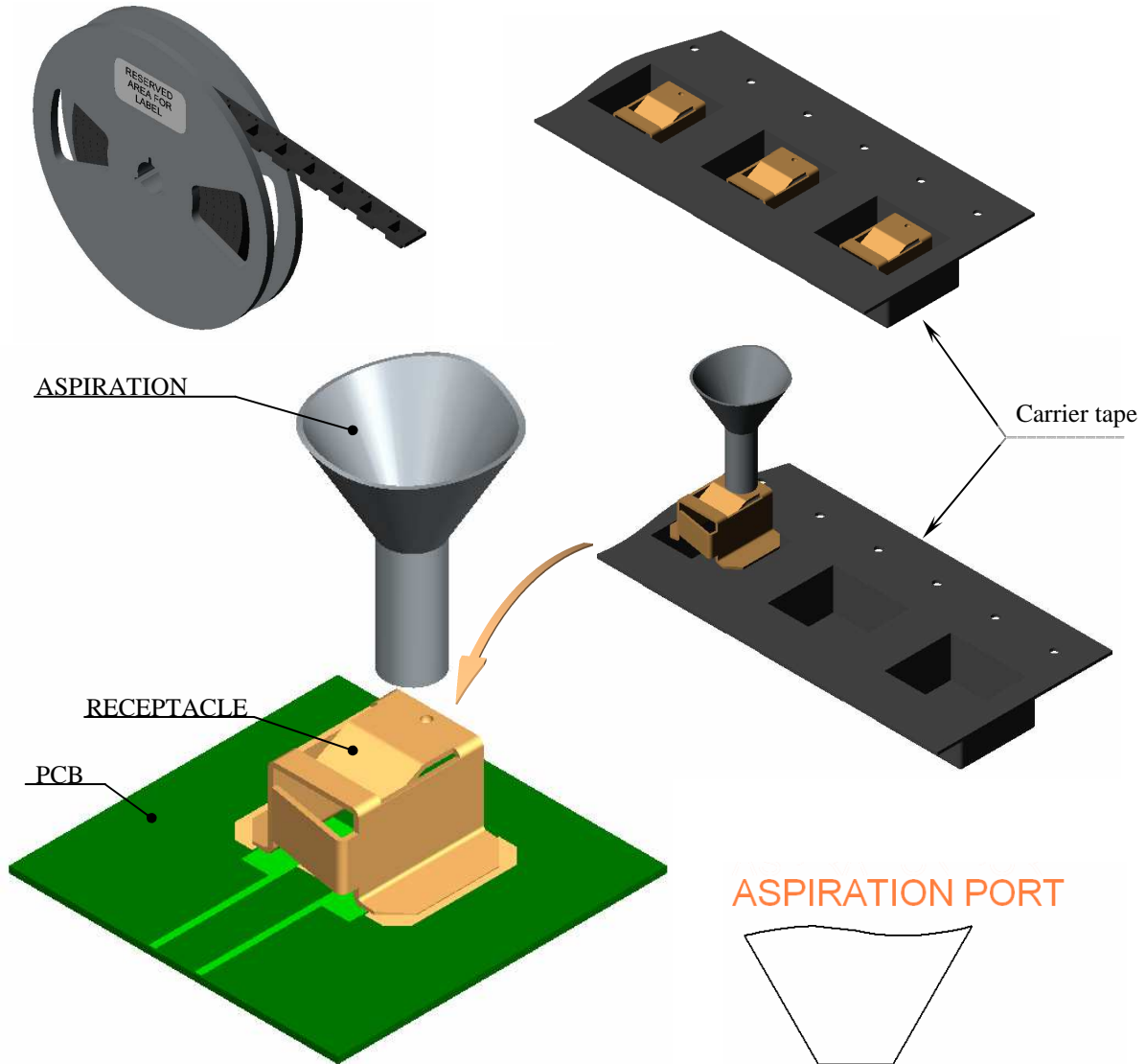

Issue : 0707 A

In the effort to improve our products, we reserve the right to make changes judged to be necessary.



**RIGHT ANGLE H2.6 RECEPTACLE NON-MAGNETIC
SMT TYPE
REEL 3300**

R107.103.087

Series : UMP

UMP CONNECTING NOTE

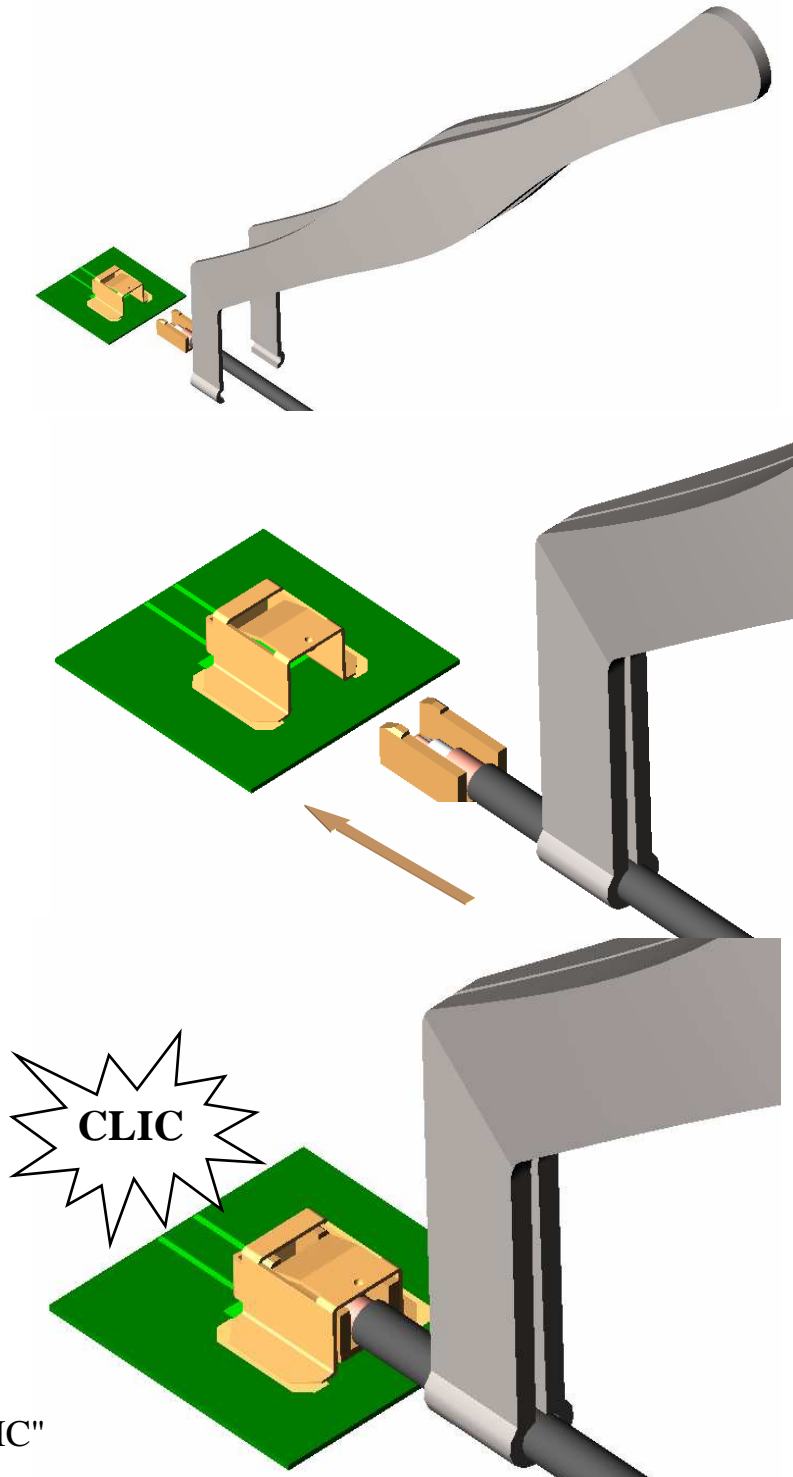

Do not push
Over the " CLIC "

Issue : 0707 A

In the effort to improve our products, we reserve the right to make changes judged to be necessary.



**RIGHT ANGLE H2.6 RECEPTACLE NON-MAGNETIC
SMT TYPE
REEL 3300**

R107.103.087

Series : UMP

UMP CONNECTING NOTE

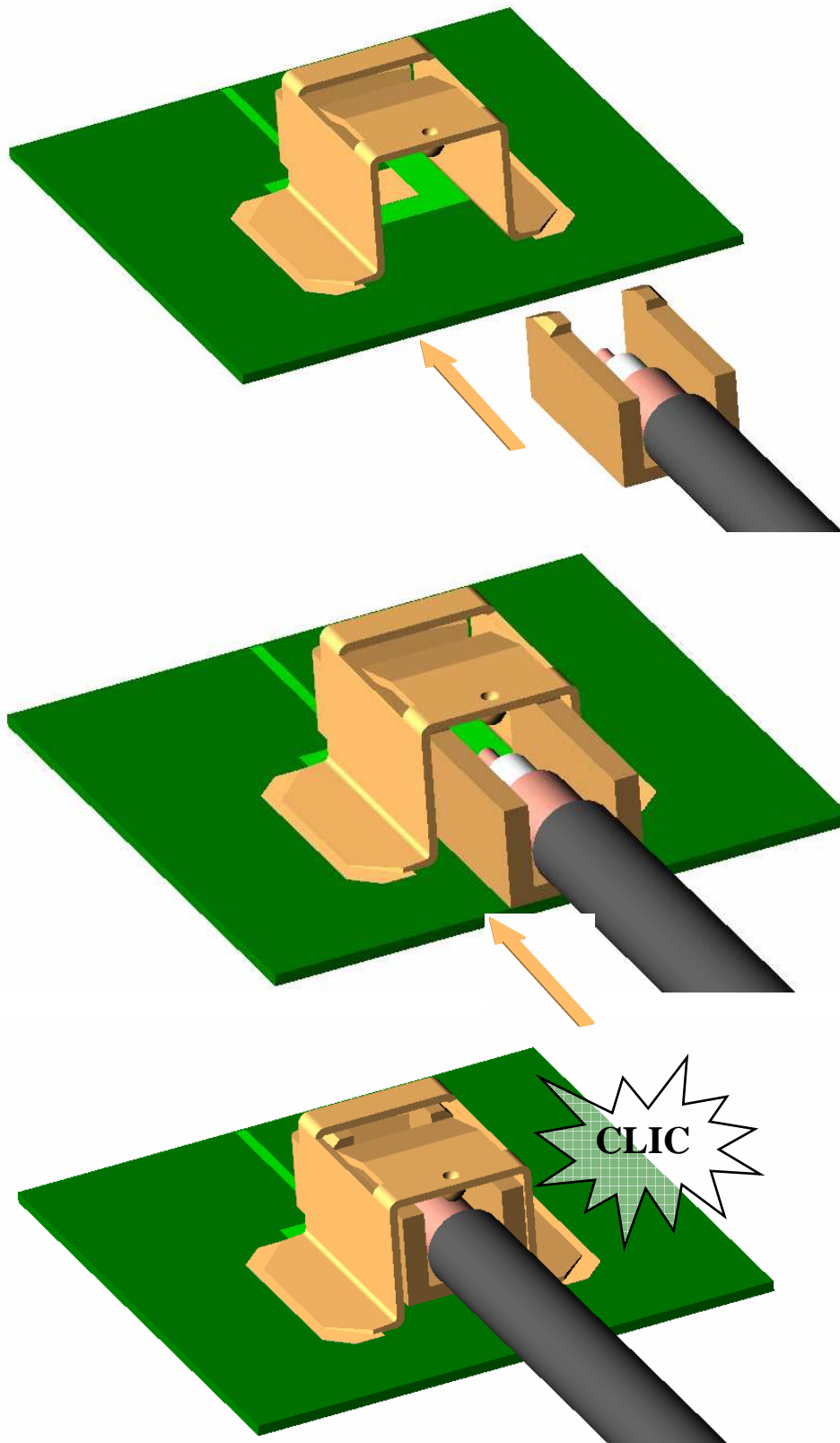

Issue : 0707 A

In the effort to improve our products, we reserve the right to make changes judged to be necessary.



RADIALL®

**RIGHT ANGLE H2.6 RECEPTACLE NON-MAGNETIC
SMT TYPE
REEL 3300**

R107.103.087

Series : UMP

UMP DISCONNECTING NOTE

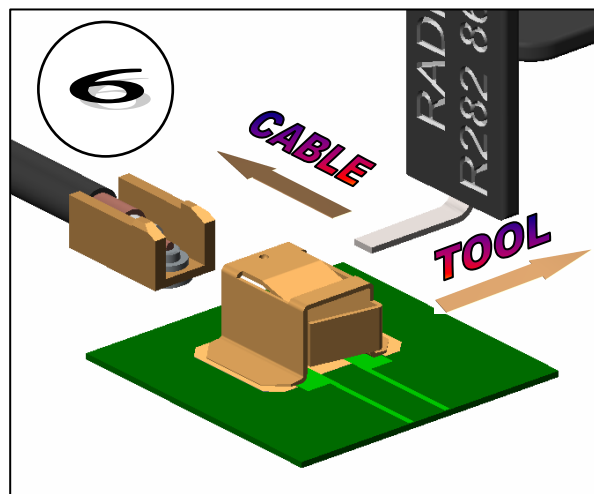
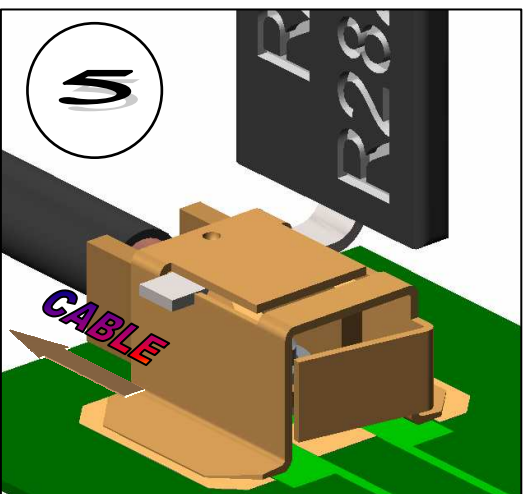
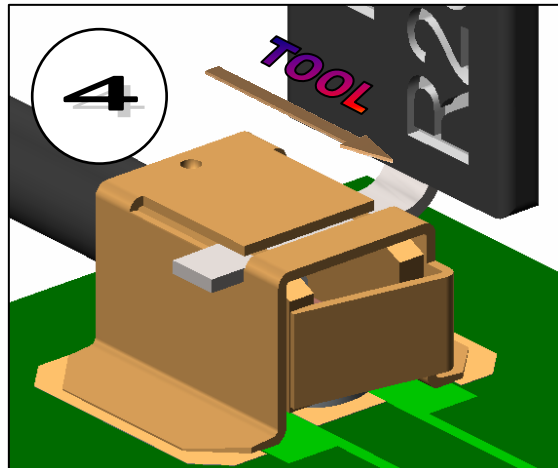
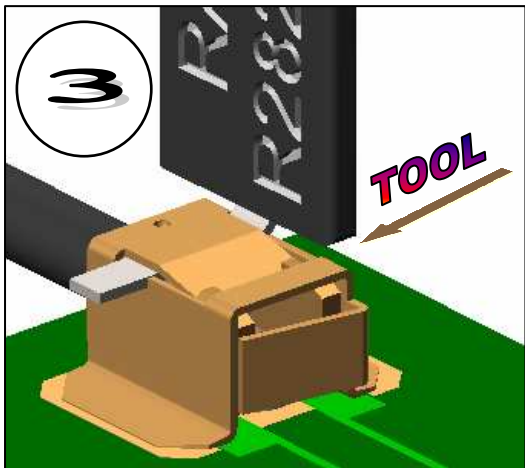
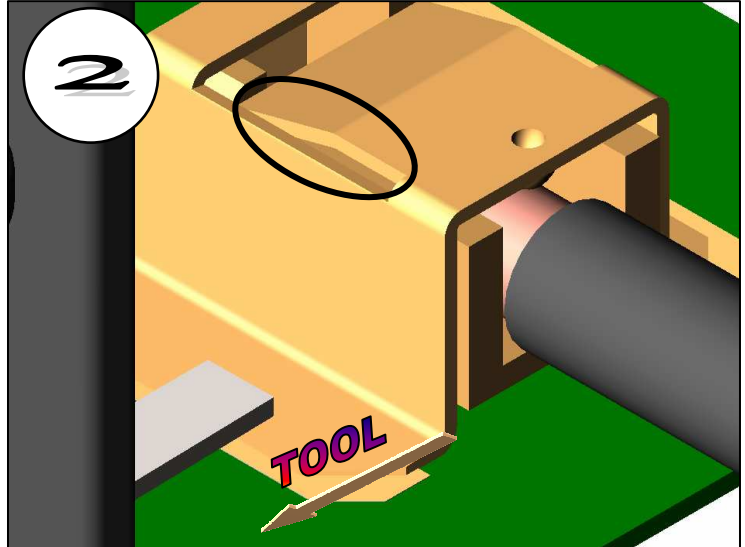
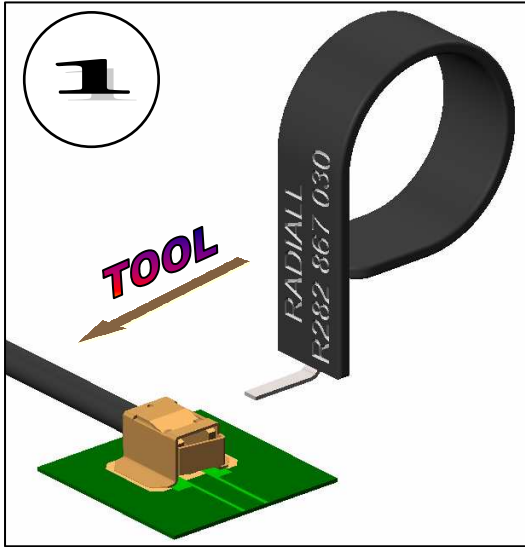

Issue : 0707 A

In the effort to improve our products, we reserve the right to make changes judged to be necessary.

